

MODEL PAD 35-30
REGULATED DC POWER SUPPLY
OPERATION MANUAL

KIKUSUI ELECTRONICS CORP

CONTENTS

| | PAGE |
|---|------|
| 1. GENERAL DESCRIPTION | 1 |
| 2. SPECIFICATIONS | 2 |
| 3. OPERATION | 5 |
| 3.1 Front panel description | 5 |
| 3.2 Precaution | 8 |
| 3.3 How to use sampling terminals | 9 |
| 3.4 Constant-voltage, current characteristics | 11 |
| 3.5 Transient response | 12 |
| 3.6 Single operation | 12 |
| 3.7 Series connection | 13 |
| 3.8 Parallel connection | 15 |
| 3.9 One-control parallel operation | 17 |
| 3.10 Remote control | 19 |
| 3.11 Internal temperature detecting circuit | 21 |

* BLOCK DIAGRAM

1. GENERAL DESCRIPTION

Kikusui Electronics' Model PAD 35-30 is an all-silicon-transistorized, highly reliable, variable regulated DC power supply which has excellent regulation, a low temperature coefficient and fast transient response. It is a universal type usable for either a digital or analog circuit. Since a pre-regulated circuit is built-in, overheating of the entire instrument is suppressed and also Model PAD 35-30 employs a forced air cooling system with a fan. Therefore, the instrument is compact and light-weight in comparison with the conventional instruments although it is of natural cooling type.

The output voltage is adjustable precisely and smoothly over a range of zero to 35V with a 5-turn vernier type variable resistor. The maximum output current is 30A. Model PAD 35-30 can be used as a constant current power supply over a range of 0.5 to 30A. Use of a new circuit technique permits the constant current characteristic to be improved largely, as compared with the conventional type. Model PAD 35-30 is a constant voltage-current automatic crossover type in which the constant output voltage performance and constant current performance are changed over automatically according to load variation. Two lamps mounted on the front panel indicate the respective operation modes alternately (constant voltage or constant current).

Model PAD 35-30 is not only used in single operation but in series, parallel or one-control parallel operation by which the voltage or current can be expanded. Use of an external resistor also permits the output voltage to be remote-controlled.

2. SPECIFICATIONS

| | |
|-----------------------------------|--|
| AC input | 200V \pm 10% AC, 50/60 Hz |
| Full load | Approximately 3.2 kVA |
| Dimensions | Case 430W x 319H x 400D mm* |
| Maximum | 431W x 340H x 490D mm |
| Weight | Approximately 51 kg |
| Ambient temperature | 0 ~ 40°C |
| Accessories supplied | Short bar 1 set Fuse conventional, 30A 2 Operation manual 1 |
| Output | |
| Terminals | Color coded, aligned horizontally; 5 terminals on the rear panel (-sampling, -, GND, +, +sampling). Obtainable from the front and rear panels. |
| Polarity | Positive or negative |
| Floating voltage | \pm 150V maximum |
| Cooling system | Forced air cooling |
| Constant voltage characteristics: | |
| Voltage | 0 ~ 35V continuously variable with 5-turn variable resistor. |
| Current | 30A |

Ripple noise (5 Hz - 1 MHz) 500 μ V rms

Voltage regulation (when the sampling terminals are used)

Line regulation 0.005% + 1 mV against $\pm 10\%$ variation of line voltage

Load regulation 0.005% + 2 mV against 0 - 100% variation of output current

Transient response (10 - 100%) Typical value 100 μ s

Temperature coefficient Typical value 100 PPM/ $^{\circ}$ C

Constant current characteristics:

Voltage 0 - 35V continuously variable with 5-turn variable resistor

Current 0.5 - 30A continuously variable

Ripple noise (5 Hz - 1 MHz) 2 mA rms

Current regulation

Line regulation 3 mA against $\pm 10\%$ variation of line voltage

Load regulation 5 mA against 0 - 100% variation of output voltage

Operation

Series operation

Parallel operation

One-control parallel operation

Output voltage remote control

Operation mode indication

LED Indication by light emitting diode

Constant voltage C.V.

Constant current C.C.

Internal temperature detecting circuit

When the internal temperature exceeds, this built-in circuit automatically shuts off the output circuit.

Voltmeter DC 35V accuracy 2.5% of full scale

Ammeter DC 35A accuracy 2.5% of full scale

* Can be installed on 19 in. or 500 mm standard rack using brackets.

3. OPERATION

3.1 Front panel description (See Figs. 3-1 and 3-2.)

- | | | |
|---|----------------------------|---|
| ① | POWER switch | ON/OFF switch for the input power. The upper position is ON. An electromagnetic switch (breaker) is employed. |
| ② | Pilot lamp | Indicates ON-OFF state of input power. The lamp turns on when the power is ON. |
| ③ | Constant voltage indicator | Indicates that Model PAD 35-30 is in the constant voltage mode: (C.V.) |
| ④ | Constant current indicator | Indicates that Model PAD 35-30 is in the constant current mode: (C.C.) |
| ⑤ | VOLTAGE | Knob for setting the output voltage. Clockwise rotation increases the output voltage. |
| ⑥ | CURRENT | Knob for setting the output current. Clockwise rotation increases the output current. |
| ⑦ | Voltmeter | Indicates the output voltage. DC 35V Accuracy is 2.5% of the full scale. |
| ⑧ | Ammeter | Indicates the output current. DC 35A Accuracy is 2.5% of the full scale. |

- ⑨ Output terminals Aligned in the following order: from the left, -SAMPLING (white), - (white), GND (black), + (red), +SAMPLING (red).
- ⑩ Rear terminal plate (1) Output terminals, sampling terminals, GND terminals and input power terminals are provided.
- ⑪ Rear terminal plate (2) Remote control terminal and one-control parallel operation terminals are provided.
- ⑫ Air intake hole

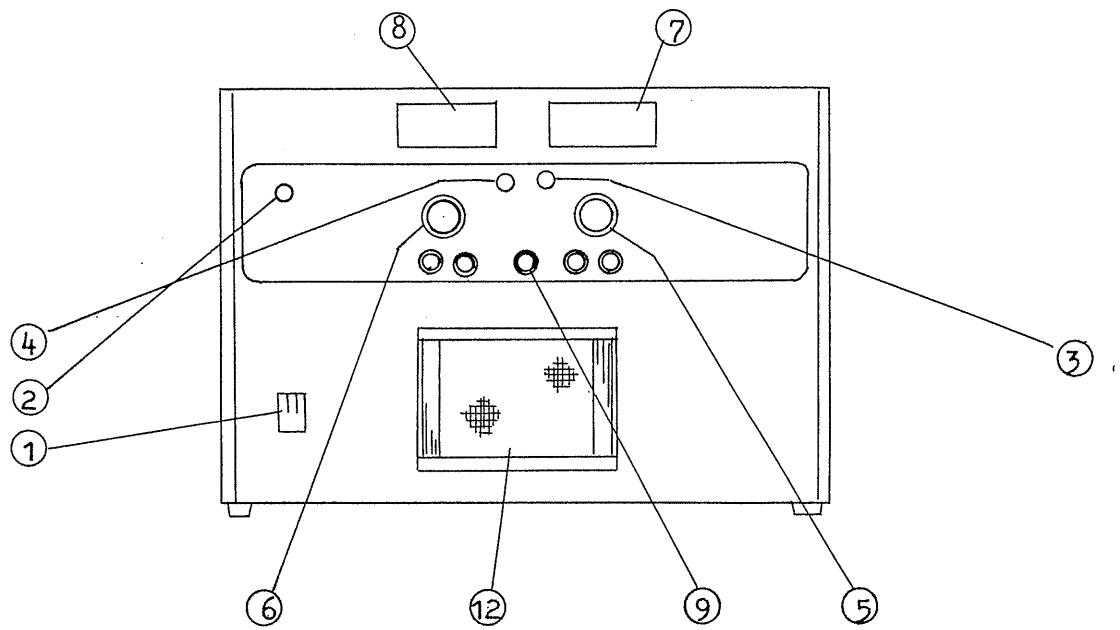

Fig. 3-1 Front panel

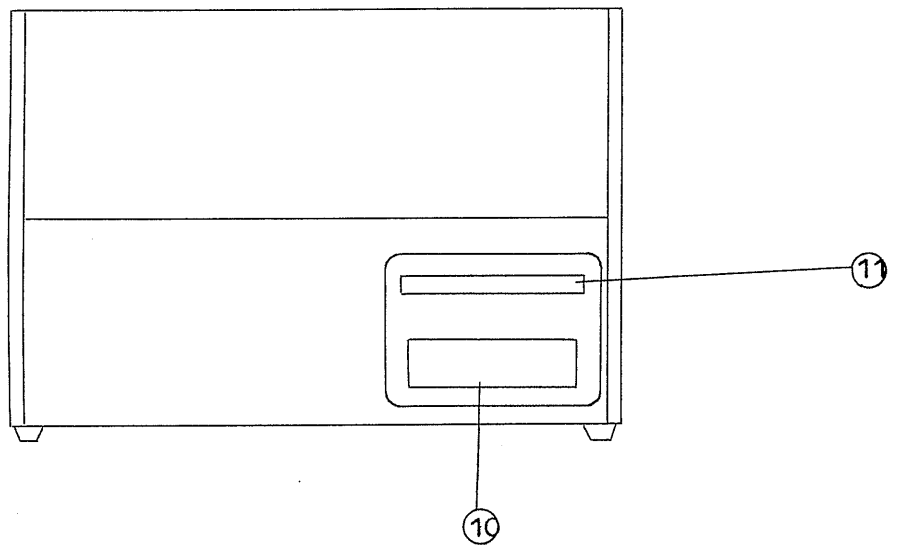

Fig. 3-2 Rear panel

3.2 Precaution

In using Model PAD 35-30, pay attention to the following:

(1) Input power:

Ensure that the input power is 200V \pm 10% AC, 48-62 Hz, and that the power line has a sufficient capacity. (See the characteristic curve illustrated at the end of this manual.)

(2) Location:

The place of use must not be of the following conditions.

- o Exposed to heat radiation source.
- o Ambient temperature is within 0 to 40°C.
- o Atmosphere is highly humid and dusty.
- o The surface is not flat.

Note that heat radiation is impeded and the power supply may be damaged if it is used being laid on its side or an object is placed on its top.

When two or more power supplies are used being stacked or installed on a rack, provide a gap of 50 mm or more between two adjoining power supplies.

(3) Output voltage setting knob:

The vernier-type potentiometer used to control the output voltage is an endless type. When the knob is rotated more than 5 turns, the rotation becomes heavy. This point signifies the end point of electrical adjustment.

(4) Overshoot:

The output voltage of the power supply never exceeds the set voltage, even as transients when the input power is turned on and off.

(5) Parallel operation:

When two (or more) power supplies are operated in parallel, a potential difference may be produced between chassis due to unbalance of the internal line filters. In such a case, connect together the GND terminals of the power supplies. The potential difference does not cause any damage or hazards.

3.3 How to use sampling terminals

When Model PAD 35-30 is far from the load, a long lead connecting the output terminals and the load causes load regulation to be deteriorated because of voltage drop due to lead resistance. The sampling terminals serve to solve this trouble. For the connection diagram, see Fig. 3-3.

- (1) Disconnect the short bars from -SAMPLING, - and +, and +SAMPLING terminals on the front panel. Remove the jumpers between -S, - and +, and +S terminals on the rear terminal board (1).
- (2) Connect the output terminals on the rear or front panel to the load. Connect the sampling terminals and the nearest load terminals with other leads. Match the polarity of the sampling terminals to that of the output terminals.

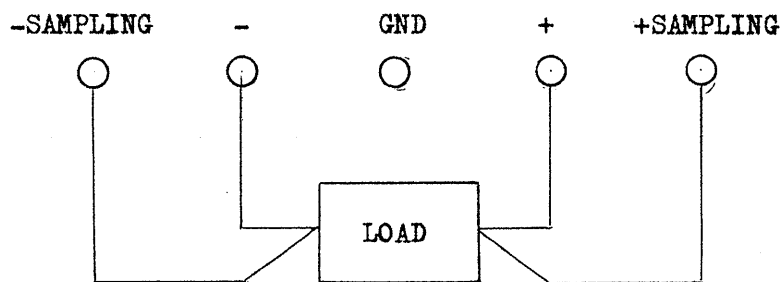

Fig. 3-3

Note 1: Deterioration of load regulation is calculated by the following formula;

$$V_d = I_o \times R \text{ (m}\Omega\text{)}$$

where

I_o (A) = Load current, R (m Ω) = lead resistance

V_d = Voltage drop

- Note 2: Use two-conductor shielded wire for sampling to avoid induction causing ripple from outside. Check the sampling leads for proper polarity.
- Note 3: Be careful since the lead connected to the load affects the preset constant current value due to its resistance.
- Note 4: As long sampling leads tend to cause oscillation, connect electrolytic condenser with a capacitance of a few μF 's with working voltage of 63V or more to sampling terminals in the proper polarity.
- Note 5: Sampling is impossible if voltage drop of the lead connected to the load is 0.3V or more.

3.4 Constant-voltage, current characteristics

The working output characteristic of Model PAD 35-30, called constant-voltage/constant-current automatic crossover type, permits continuous transition from constant-current to constant-voltage operation mode in response to the load change.

The intersection of constant-voltage and constant-current operation modes is called crossover point. Fig. 3-4 shows the relationship between this point and the load.

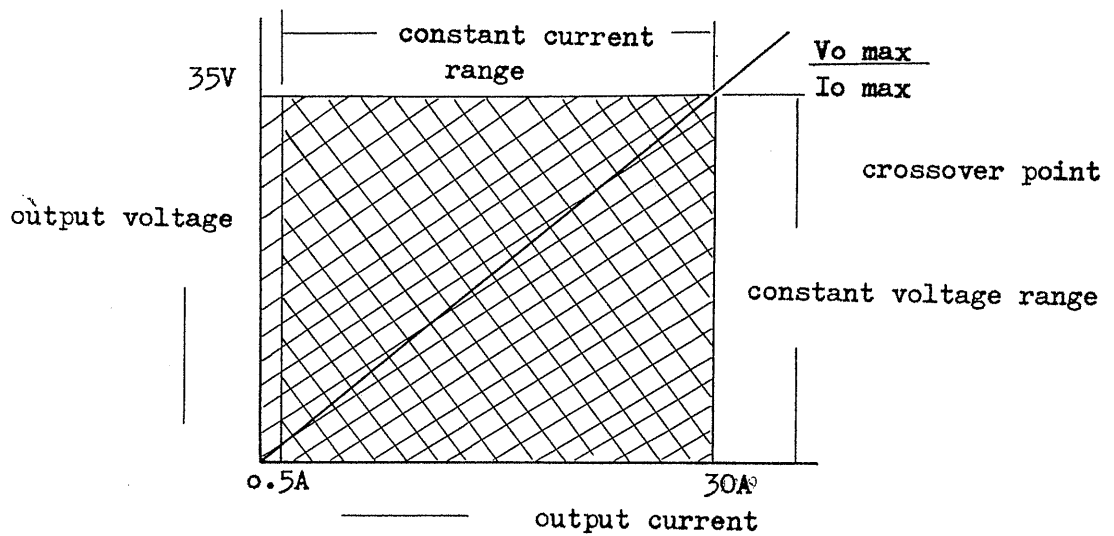

Fig. 3-4

The operation modes of PAD 35-30 are indicated by the area with oblique lines. Operation is possible anywhere within this area.

3.5 Transient response

Designed to meet a transient response quickly enough, PAD 35-30 can be used for digital or other circuits involving a drastic load variation and in which performance is affected by a transient variation. But this is the characteristic at the output terminals, and if a long lead is extended to the load, then influence of the inductance is not negligible. In such a case, use capacitors to cancel the inductance.

3.6 Single operation

Constant voltage performance

- 1) Connect the power cord. Throw the power switch upwards, and Model PAD 35-30 is ready to operate immediately, lighting the pilot lamp simultaneously.
- 2) Turn CURRENT knob fully clockwise. Turn VOLTAGE knob until the desired voltage is obtained. (Clockwise rotation increases the output voltage.)
- 3) Connect the output terminals to the load.

Note: When requiring limiting the load current to a certain value. Before the load connect, short the output terminals. Set "CURRENT" knob to the desired current value.

Constant current performance

- 1) The same as Paragraph (1) in "Constant voltage performance" above.
- 2) Turn "VOLTAGE" knob clockwise until its motion becomes slightly rough. (This implies the maximum output voltage.)

- 3) Short the output terminals. Turn "CURRENT" knob until the desired current value is obtained. (Clockwise rotation increases the output current.)
- 4) The same as Paragraph 3 in "Constant voltage performance" above.

Note 1: Model PAD 35-30 is a constant voltage-current automatic crossover type. When the load current is smaller, the constant current mode is changed over to the constant voltage mode at a specific voltage. Thus, when requiring limiting the output voltage to a certain value, preset the output voltage to the desired value.

Note 2: The constant voltage or constant current mode is indicated by the respective lamps on the front panel alternately.

Constant current mode lamp C.C.

Constant voltage mode lamp C.V.

Note 3: For use of the sampling terminals, see Note 3 in Chapter 3.4 "How to use sampling terminals".

3.7 Series connection

A higher output voltage than 35V can be obtained by connecting two Model PAD 35-30s in series.

Note 1: Be careful not to ground the positive terminal of one Model PAD 35-30 when grounding the negative terminal of the other in Fig. 3-5.

Note 2: The voltage at each output terminal should not exceed the floating voltage.

Note 3: Avoid the series connection with other model.

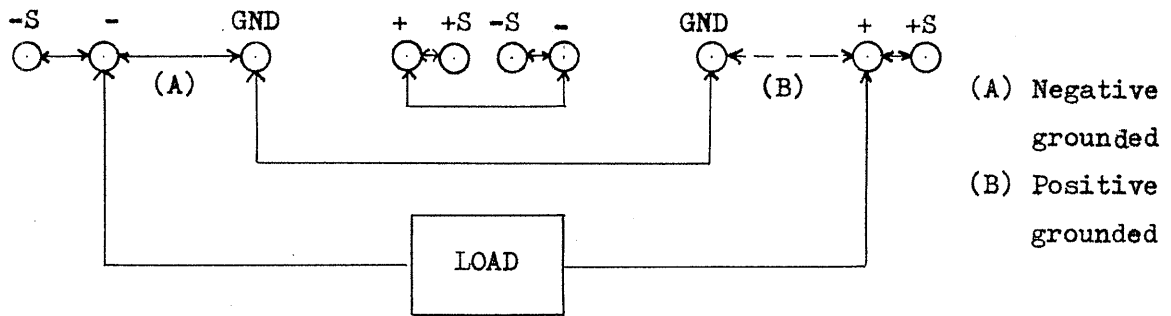

Fig. 3-5 Series connection diagram

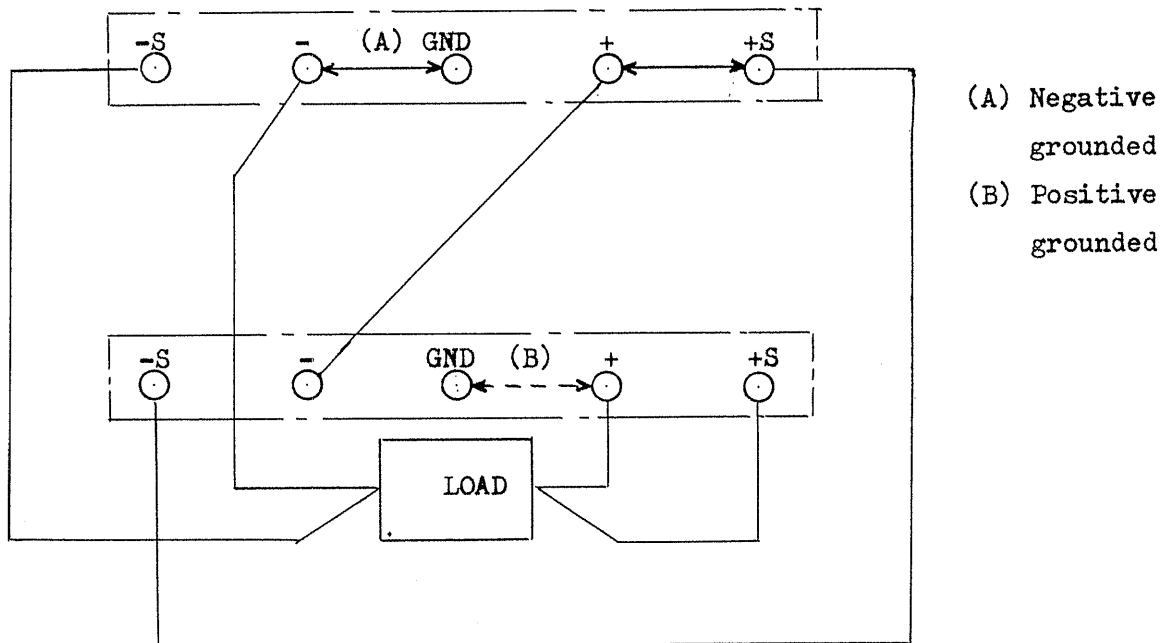

Fig. 3-6 Sampling terminal connection diagram in series connection

When two Model PAD 35-30 connected in series are overloaded, one Model PAD 35-30, which has been changed over to the constant current mode first, would be supplied with the output voltage of the other inversely. This would damage series transistors of the former. To avoid this trouble, a diode is connected between the output terminals of each Model PAD 35-30, as shown in Fig. 3-7.

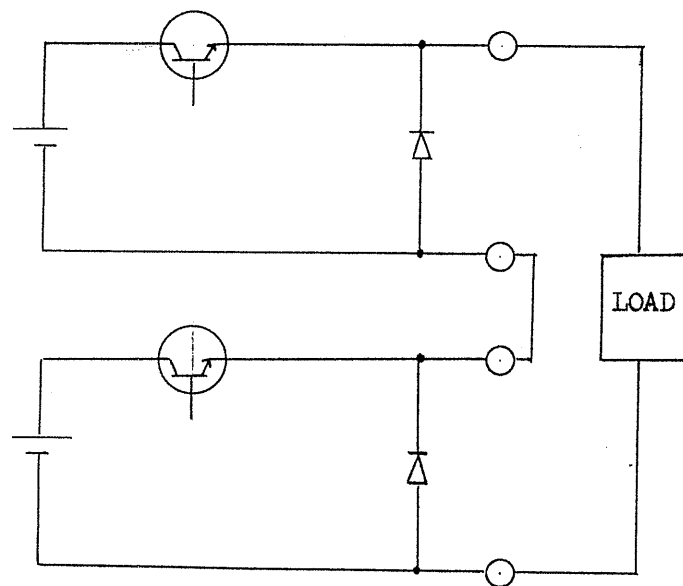

Fig. 3-7

3.8 Parallel connection

When a larger current than 30A is required, connect the output terminals of two Model PAD 35-30 in parallel.

- 1) Set the output voltages of the two Model PAD 35-30 in parallel connection at values as close as possible each other since a setting difference between the two would cause load fluctuation.
- 2) Turn "CURRENT" knobs fully clockwise.

- 3) Connect the output terminals of two Model PAD 35-30 to the load so that their polarity matches. The grounding polarity of both should also match.

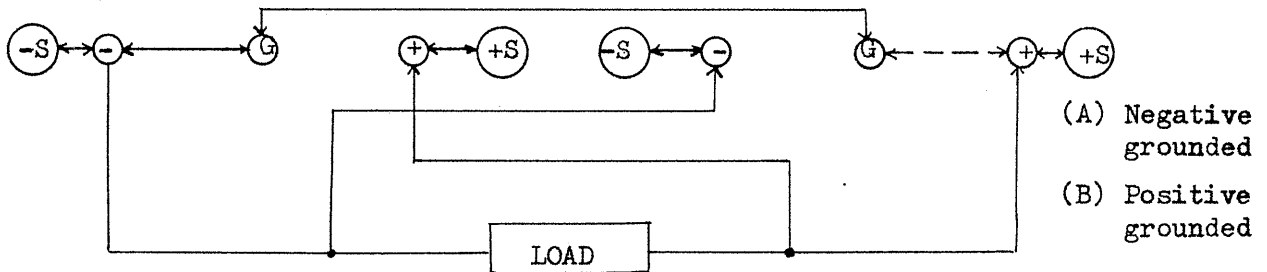

Fig. 3-8 Parallel connection diagram

Voltage-current characteristics in parallel connection

As the voltage-current characteristics in parallel connection in Fig. 3-9 show the output voltage in parallel operation remains constant until one Model PAD 35-30 with a higher output voltage is overloaded. When one Model PAD 35-30 is changed over to the constant current mode, the output voltage decreases until it reaches the value preset by the other Model PAD 35-30, whose output terminals are changed over from an inverse voltage condition to a normal one, causing the constant voltage mode. Thus, load fluctuation causes the output voltage to fluctuate by the preset output voltage difference V between the two units, and ripple characteristics are reduced.

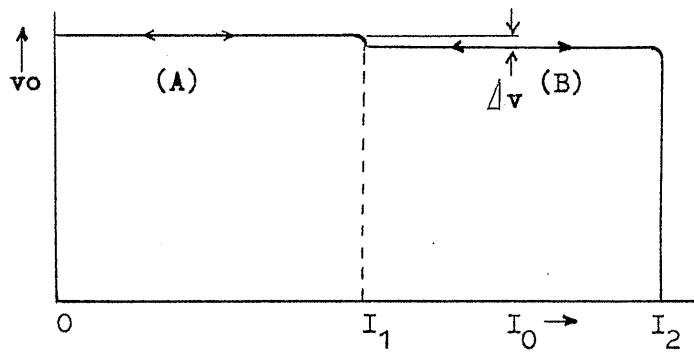

Fig. 3-9 Characteristics diagram

3.9 One-control parallel operation

When a larger current than 30A is required, one-control parallel operation of two Model PAD 35-30 is preferable since the characteristics are improved largely, as compared with those in parallel connection.

In one-control parallel operation, one of the Model PAD 35-30 operates as the master unit, by which the output voltage is adjusted, and the other as the slave whose output voltage is controlled by the master unit.

- 1) Connect the terminals on the rear panel of the master to the slave and the load as shown in Fig. 3-10.
- 2) Pick up the output at the output terminals on the rear panel of the master. When turning on the power or output switches of the master and slave, start with the master. When turning them off, start with the slave.

Note 1: Picking up the output on the output terminals on the front panel of the master causes load regulation to be deteriorated somewhat, and current unbalance occurs between the master and slave.

Note 2: To prevent load regulation from increase, use the sampling terminals. (Connection is showed Fig. 3-11.)

Note 3: Turn "VOLTAGE, CURRENT" knob of the slave fully clockwise.

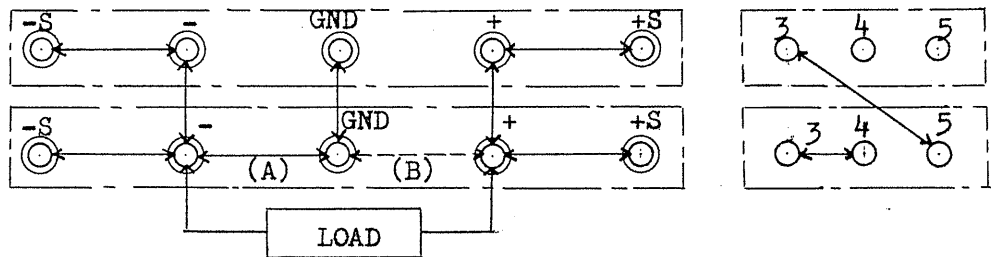

Fig. 3-10 One-control parallel operation master, slave, load

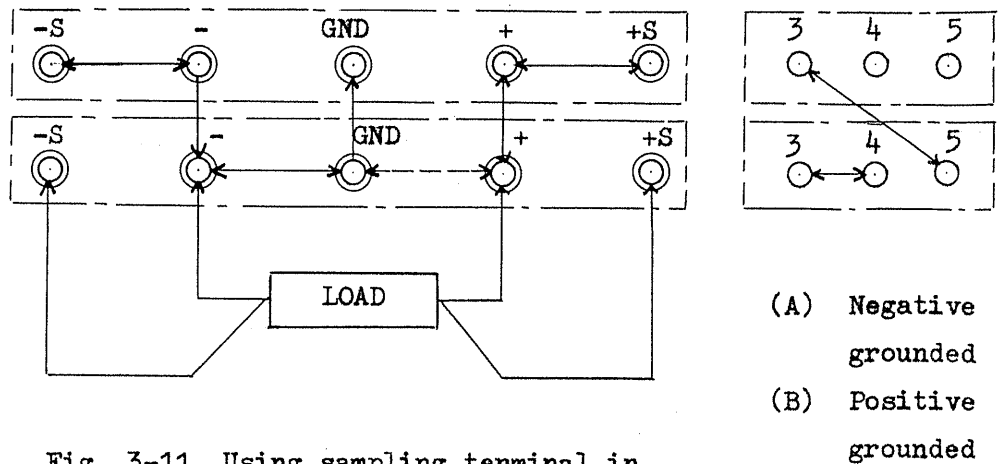

Fig. 3-11 Using sampling terminal in one-control parallel operation

3.10 Remote control

To vary output voltage by remote control, improve efficiency in varying output voltage and obtain the preset output voltages simply by operation of switches or others, use the remote control terminals on the rear panel.

- 1) Turn off power switch and remove jumpers from terminals (1) and (2) on the rear panel.
- 2) Provide a suitable variable element between (1) and -S.

Note: Variable element will be described in detail later.

- 3) Turn on power switch and then output voltage will vary according to the characteristic of the variable element connected.

Note: If the line connected to variable element is open, output voltage cannot be controlled, and excessive output voltage is detected. Make the connection with power switched off.

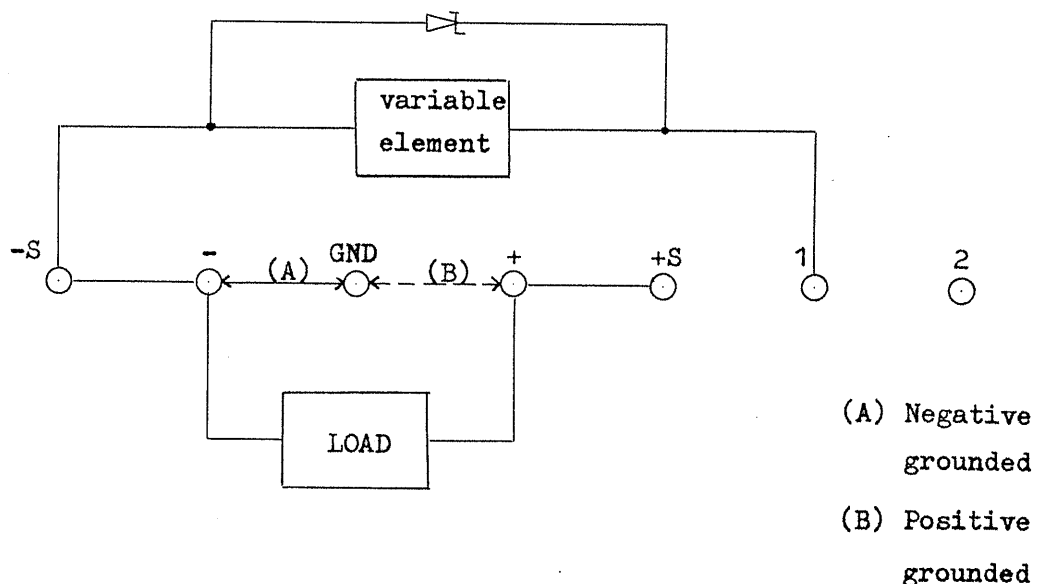

Fig. 3-12

3.10-1 To vary output voltage by remote control.

Output voltage varies at a rate of approximately $3.5V/k\Omega$ with reference to the resistance of the resistor connected.

Therefore,

$$\text{Output voltage } V_o (V) = \text{Voltage variation rate } 3.5V/k\Omega \times R_r (k\Omega)$$

where voltage variation rate indicates voltage change for each $1 k\Omega$, and R_r the resistance ($k\Omega$) for remote control.

If no suitable resistor is available and output V_o may exceed the rated output or it is desired to fix voltage at a certain level, output voltage can be limited by connecting zener diode with a small leakage current to the resistor. (See Fig. 3-12)

Note 1: Use a wire wound type variable resistor with a low temperature coefficient or a metal-film one, and the power rating of such a resistor must be at least $0.5W$ more over. Otherwise, the temperature drift of output voltage may deteriorate.

Note 2: PAD 35-30 can operate steadily if the external lines connected are limited to approximately $2m$. If longer lines are used, output voltage may become unstable.

3.10-2 To improve efficiency in varying output voltage (to finely adjust voltage).

As already mentioned, output voltage is proportional to the external resistance.

Letting V_{res} stand for the required efficiency, the efficiency of the resistor can be formulated as follows.

$$R_{res} = \frac{V_{res}}{\text{Voltage variation rate } 3.5V/k\Omega} (k\Omega)$$

3.11 Internal temperature detector circuit

When the internal temperature exceeds preset limit, the built-in circuit automatically shuts off the output circuit. Therefore, if this instrument is used in a place where the ambient temperature is over 40°C, or used by mounting it on another instrument, the entire output or current may not be obtained. Since this circuit is restored to its original condition soon after the internal temperature lowers below the specific value, turn off the power switch, and cool the instrument if the output cannot be obtained as specified while the circuits operate normally.

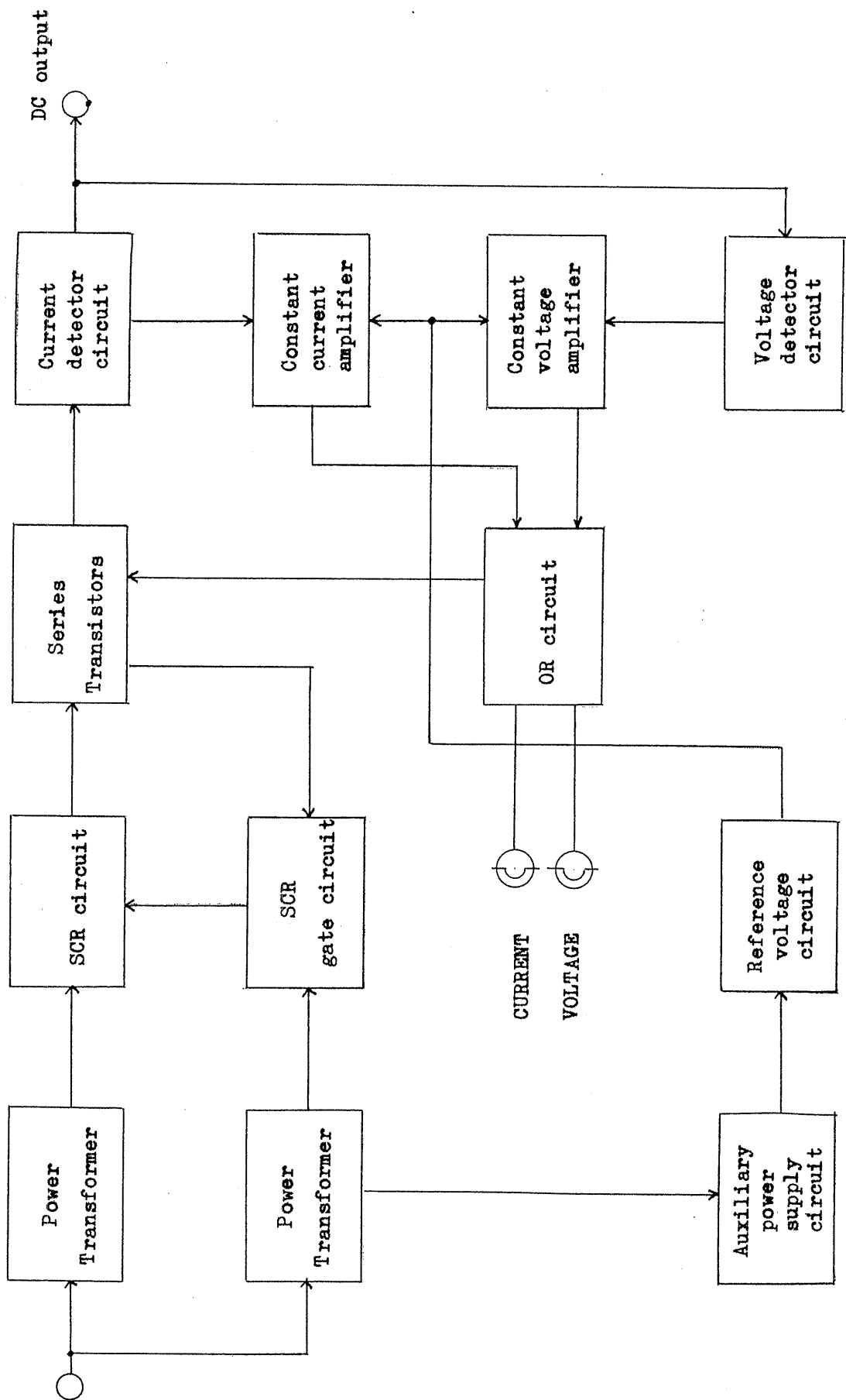
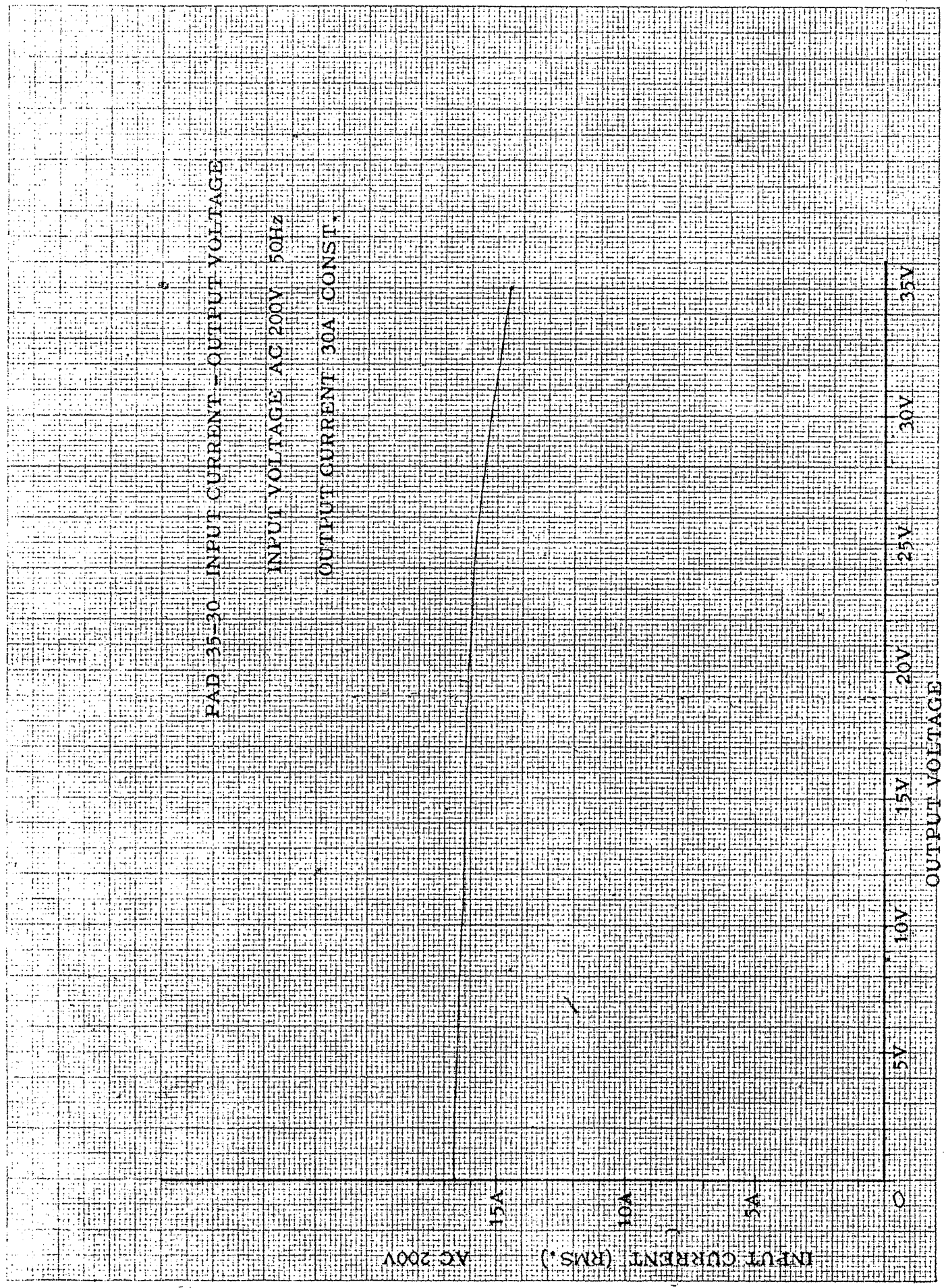

Fig. 4-1 Block diagram

S-731046



FAD 35-30 INPUT CURRENT - OUTPUT VOLTAGE

INPUT VOLTAGE AC 200V 50Hz

OUTPUT CURRENT 30A CONST.

AC 200V

INPUT CURRENT (RMS.)

OUTPUT VOLTAGE